

AMBIC[®]

MultiDipper (Electric)



OPERATING INSTRUCTIONS

leading best practice in livestock health management

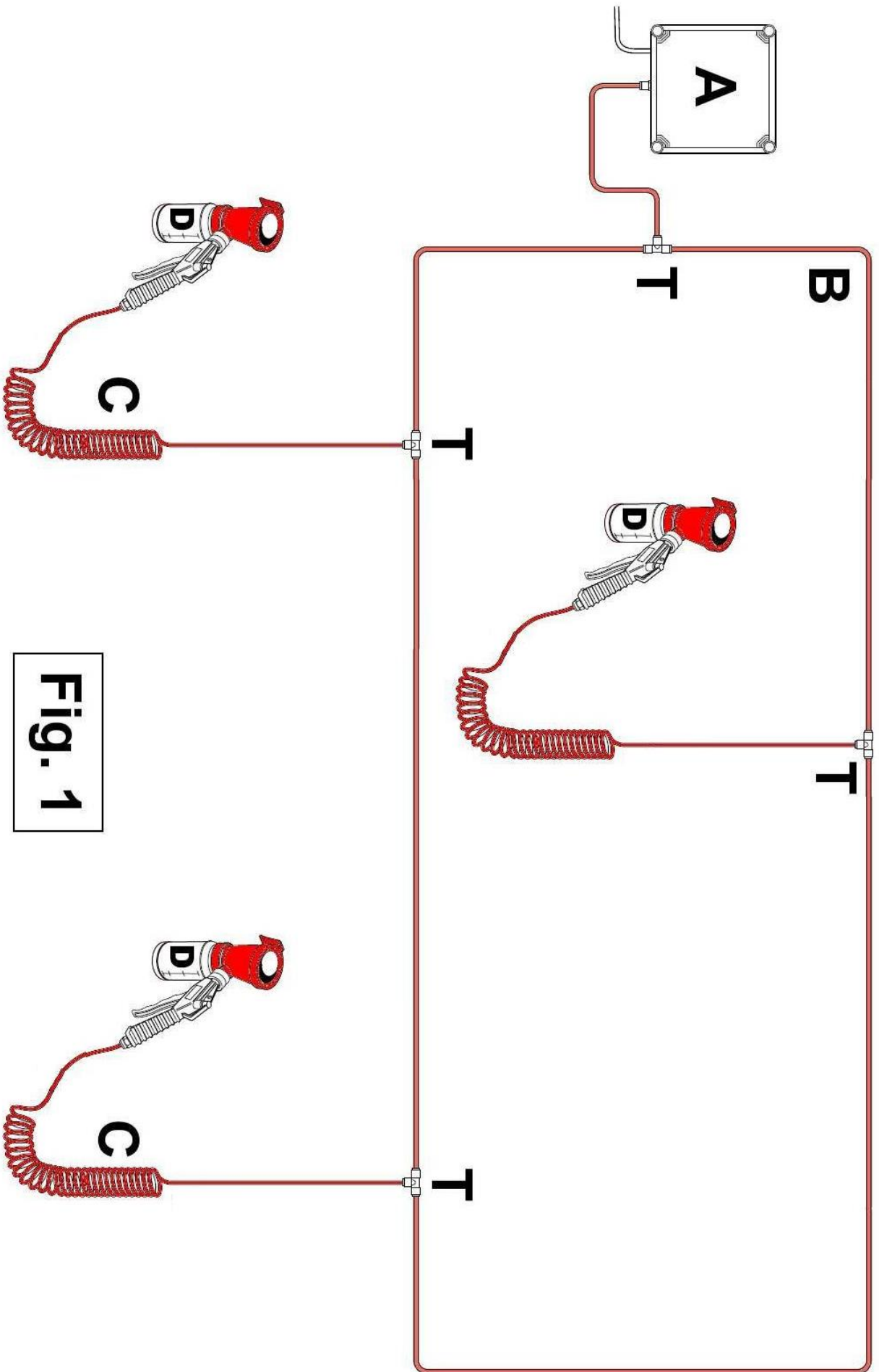

Fig. 1

SAFETY

The “MultiDipper” Teat Dipping System is designed exclusively for use in milking installations. Any application outside the use described in this operating manual will be taken to be not in accordance with the intended purpose. The manufacturer/supplier will not be held responsible for any losses arising as a result of such use. The user will take full responsibility for use. **USE IN ACCORDANCE WITH THE INTENDED PURPOSE ALSO INCLUDES COMPLYING WITH THE OPERATING MANUAL AND THE CONDITIONS FOR INSPECTION AND MAINTENANCE.**

INSTALLATION (see Fig. 1 opposite)

The “MultiDipper” unit is based on the well-proven PowerFoamer and uses an electric pumping unit to provide low pressure air (~3 psi; 0.2 Bar) for dipping cows’ teats using Dipping chemical. It is designed to be installed as a ring main system.

The enclosure housing the electrics of the “MultiDipper” is rated at IP40 (IEC 60529), the power unit (A) must therefore be positioned outside of the milking parlour in a dry location and close to a 220 - 240V AC power socket. The power supply cord **MUST** remain accessible when the unit has been installed. For drilling template refer to page 7.

Routing the ring main tube (B) will depend on the parlour design and will be either at high level or low level. If high level, it will ideally be positioned above the rump rail on each side with the coil (C) connected via a 'T' fitting (T) fixed with cable ties (H). Alternatively it can be routed along the centre of the parlour. Cable ties (H) will also be used to secure the ring main. (see Fig. 2 overleaf)

CAUTION: Do not over tighten cable ties as air flow may be restricted.

IT IS IMPORTANT that tubes are pushed fully into fittings to prevent leakage of air which may hamper the operation of the system.

Dip (D) Applicators should be positioned such that all milking points can be reached comfortably without over-stretching the coils. Extension kits are available to enable as many Applicators as required to be installed.

If no suitable horizontal bar is available on which to hang the unit, the Plastic Hanging Hook supplied may be either fitted to a suitable horizontal tube using 2 cable ties (crossed for stability), or can be drilled with 2 holes and fitted (using 2 screws) to a flat surface.

OPERATION

Dipping Cups are provided with 2 restrictors (R1, R2):

Black (R1) for non-viscous dip chemicals;

Red (R2) for viscous barrier/film-forming dips.

Unscrew bottle to fit appropriate restrictor (Fig. 3).

WARNING ! – if you use the **Red** restrictor with a non-viscous dip chemical, you are likely to receive a shower of dip chemical!

Switch on at electric socket. Power Unit (A) will be activated. When a line pressure of 3psi (0.2 Bar) is reached, the air pump will switch off via a pressure switch and will not operate until a gun is used and pressure drops.

Fill bottles (G) with suitable Dipping teat product to the 250 ml mark – do not overfill. Bottle can either be unscrewed from Applicator (J) with gun (E) attached, or after releasing from the gun bayonet (Fig 4).

When ready to dip, depress the trigger briefly until Dip chemical is level with the rim of Applicator (J) and raise fully onto teat (Fig. 5).

A full bottle of chemical (250 ml) will normally suffice to dip 25-40 cows – depending on the viscosity of chemical. Spare bottles with caps are provided so they can be ready-filled with dip chemical for use during milking.

When the milking is completed switch Off electric power supply.

MAINTENANCE

CLEAN THE DIP CUPS DAILY by detaching from gun, unscrewing the bottle then rinsing the cup out with clean warm water to remove any hairs, dirt, etc.

Use ONLY a soft dry cloth to clean the electrical enclosure housing when necessary – NEVER use a hose. If the supply cord is damaged, it must be replaced by the manufacturer, its service agent or similarly qualified persons in order to avoid a hazard.

Fig. 2

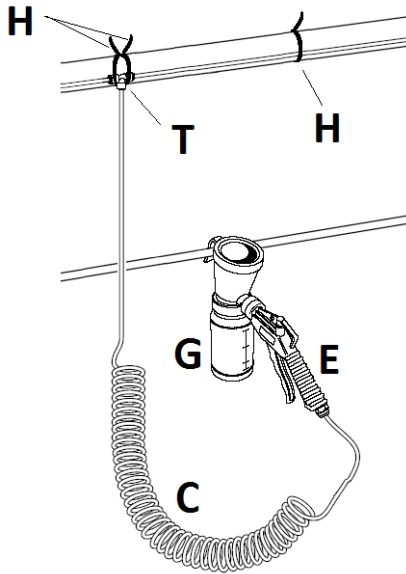

Fig. 3 - DIPPING CUP

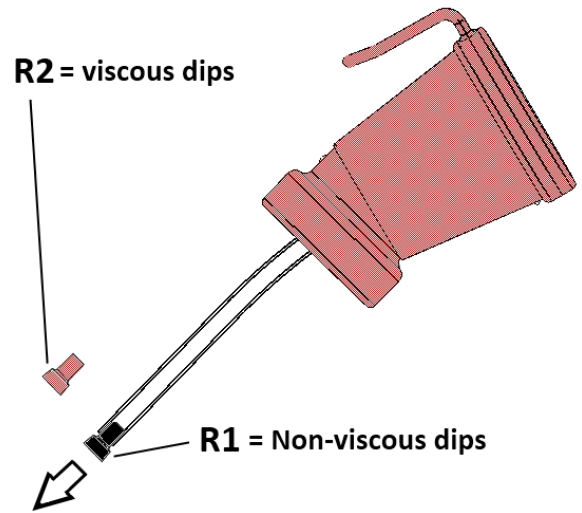

Fig. 4

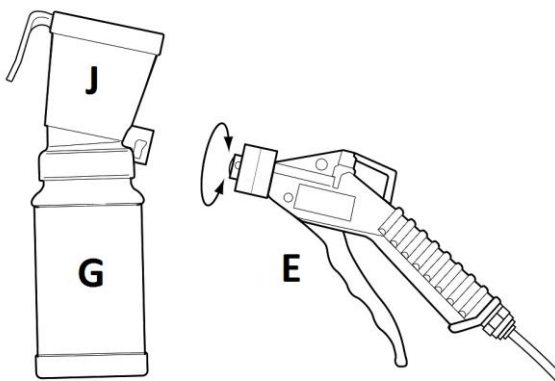
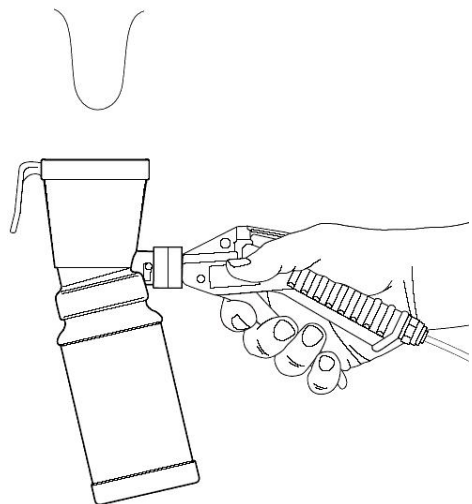

Fig. 5



SPECIFICATIONS

Power Source – Air - Electric Pumping unit	• 220-240Vac 50Hz 11W
– Fuses	• F 3.0A
Output – Air	• 5 – 8 L/min at 2 - 3 psi (0.2 Bar max.)
Maximum No. of Applicators per Pumping Unit	• 10
Maximum No. of Applicators operating simultaneously	• 2
Maximum Length of Distribution Tubing	• 45 Metres
Typical Chemical Consumption per Applicator (Dip)	• 10 -15 mL/second
Operating Temperature	• 5 – 40 °C

PROBLEMS & FAULT FINDING

WARNING - Always disconnect the supply cord from the mains power supply BEFORE removing the enclosure lid.

Problem	Likely Cause	Probable Solution
No Dip produced in cup when gun trigger squeezed (ALL units)	<p>No Air Supply present</p> <p>Pump NOT running</p> <p>Pump running continuously</p>	<p>Switch On Mains electricity supply to pumping unit.</p> <p>Check Fuses and replace if necessary.</p> <p>Disconnect the distribution tube at the outlet of the pumping unit. If pump runs then it is probable that the distribution tubing is blocked, or restricted by over-tight cable ties.</p> <p>Check for leaking connections on distribution tubing system – especially that tube fully pushed into fittings.</p> <p>Disconnect the distribution tube at the outlet of the pumping unit. If pump still runs, then check the tubing connections and non-return valve inside the pumping enclosure.</p>
No Dip produced in cup when gun trigger squeezed (at ONE unit only)	Air supply not reaching applicator.	<p>Leaking connections, or blocked tubing – check and remedy.</p> <p>Trigger valve stuck or blocked – check valve and lubricate with silicone aerosol.</p> <p>Cup dirty or blocked – clean to remove dirt, or replace with new cup.</p>

DRILLING TEMPLATE - Use the template below to mark out fixing holes for the Power unit.

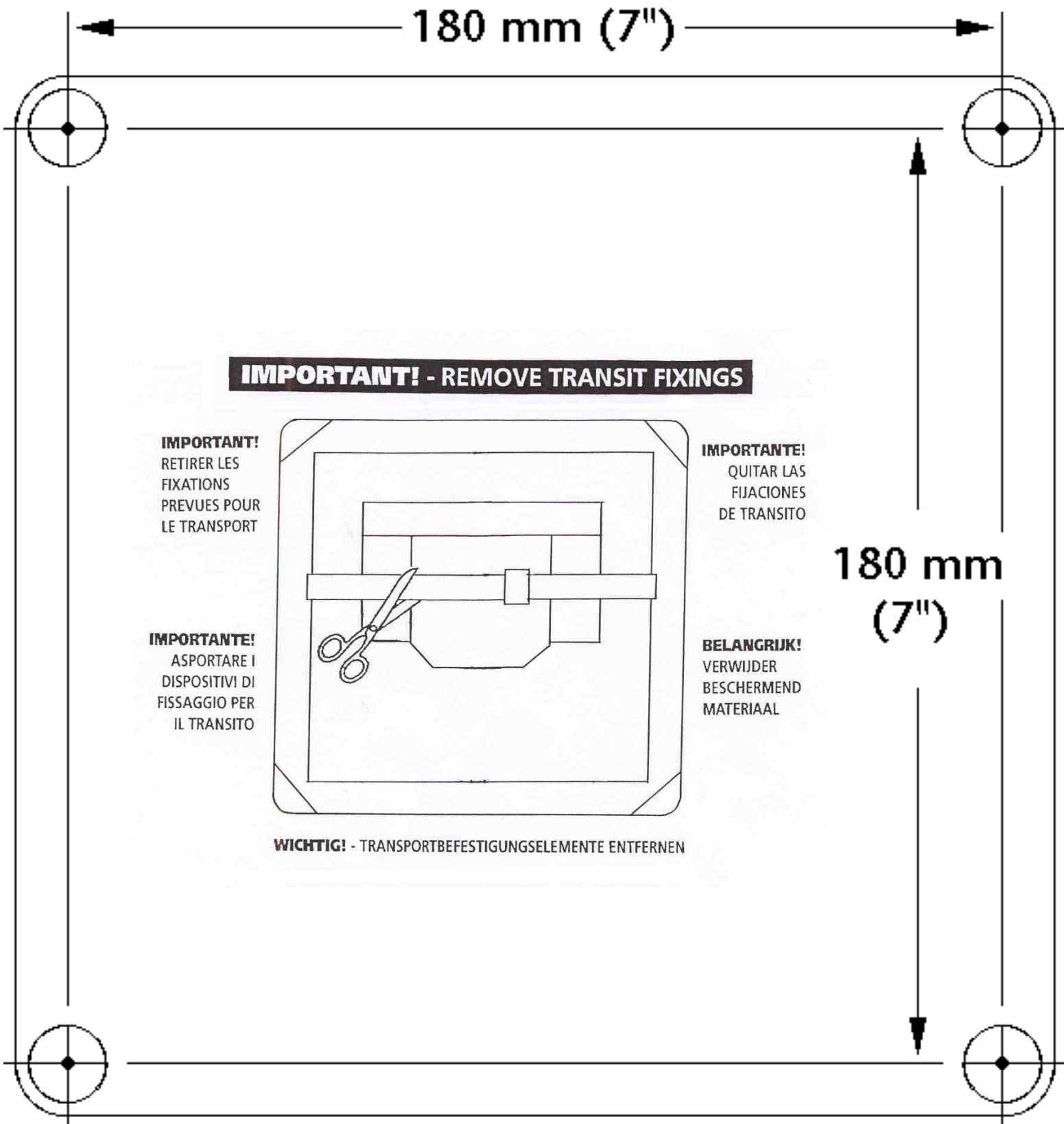



Ambic Equipment Limited,
One Parkside, Avenue Two Station Lane,
Witney, Oxfordshire, OX28 4YF, England
Tel: +44 (0)1993 776555 Fax: +44 (0)1993 779039

www.ambic.co.uk