

AMBIC®

MultiDipper (Pneumatic)



OPERATING INSTRUCTIONS

leading best practice in livestock health management

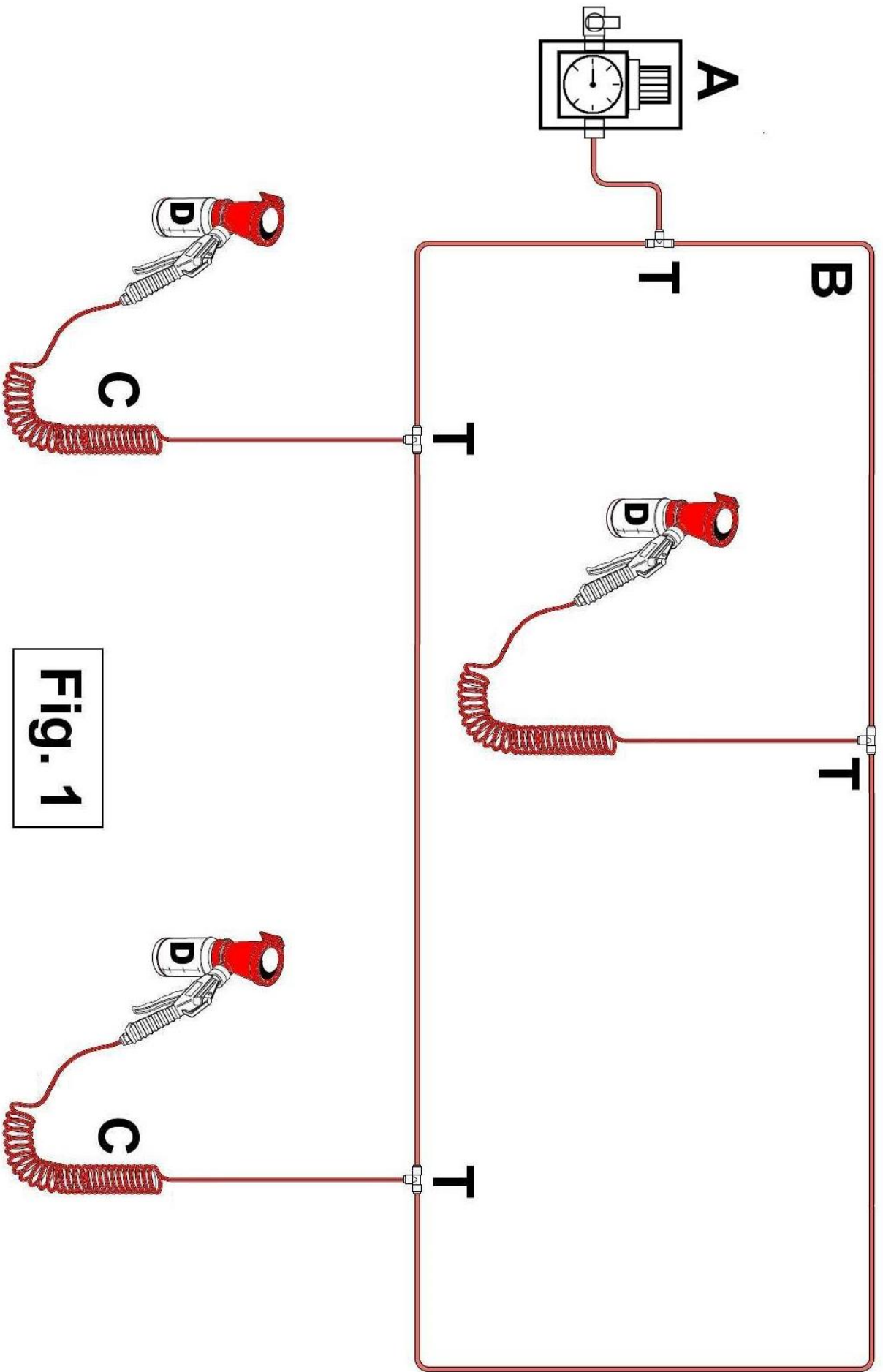

Fig. 1

SAFETY

The “MultiDipper” Teat Dipping System is designed exclusively for use in milking installations. Any application outside the use described in this operating manual will be taken to be not in accordance with the intended purpose. The manufacturer/supplier will not be held responsible for any losses arising as a result of such use. The user will take full responsibility for use. **USE IN ACCORDANCE WITH THE INTENDED PURPOSE ALSO INCLUDES COMPLYING WITH THE OPERATING MANUAL AND THE CONDITIONS FOR INSPECTION AND MAINTENANCE.**

INSTALLATION (see Fig. 1 opposite)

The “MultiDipper” unit is based on the well-proven PowerFoamer and requires a supply of compressed air to operate. The Regulator (A) supplies **LOW PRESSURE** air (3 - 4 psi; 0.2 Bar) for dipping cows’ teats using an appropriate chemical. It is designed to be installed as a ring main system.

WARNING: BEFORE connecting the Regulator to the existing compressed air system **ENSURE THAT THE AIR SUPPLY IS ISOLATED FROM THE DISTRIBUTION LINE AND THAT THE LINE IS NOT UNDER PRESSURE.**

Fit the Regulator (with adjustment knob vertically upwards) to a suitable solid wall (for drilling template see page 7).

Routing the ring main tube (B) will depend on the parlour design and will be either at high level or low level. If high level, it will ideally be positioned above the rump rail on each side with the coil (C) connected via a 'T' fitting (T) fixed with cable ties (H). Alternatively it can be routed along the centre of the parlour. Cable ties (H) will also be used to secure the ring main. (see Fig. 2 overleaf).

CAUTION: Do not over tighten cable ties as air flow may be restricted.

IT IS IMPORTANT that tubes are pushed fully into fittings to prevent leakage of air which may hamper the operation of the system.

Dip (D) Applicators should be positioned such that all milking points can be reached comfortably without over-stretching the coils. Install the Red tubes so that the coiled section is closest to the spray gun. Extension kits are available to enable as many Applicators as required to be installed.

If no suitable horizontal bar is available on which to hang the unit, the Plastic Hanging Hook supplied may be either fitted to a suitable horizontal tube using 2 cable ties (crossed for stability), or can be drilled with 2 holes and fitted (using 2 screws) to a flat surface.

OPERATION

Dipping Cups are provided with 2 restrictors (R1, R2):-

Black (R1) for non-viscous dip chemicals;

Red (R2) for viscous barrier/film-forming dips.

Unscrew bottle to fit appropriate restrictor (Fig. 3).

Switch on compressor. Remove enclosure lid of Regulator (A), open the tap and observe Pressure Gauge. Gauge should read 3-4 psi (0.2 Bar). Turn tap to OFF and check that the air pressure remains near constant. If air pressure falls rapidly, then check system for leaks and remedy.

Adjust the pressure by lifting the knob and turn clockwise to increase Pressure. Verify pressure correct with a gun operational and, when correct, press down knob to lock.

Fill bottles (G) with suitable Teat Dipping product to the 250 ml mark – do not overfill. Bottle can either be unscrewed from Applicator (J) with gun (E) attached, or after releasing from the gun bayonet (Fig 4).

When ready to dip, depress the trigger until Dip chemical is level with the rim of Applicator (J) and raise fully onto teat (Fig. 5).

A full bottle of chemical (250 ml) will normally suffice to dip 25-40 cows. Spare bottles with caps are provided so they can be ready-filled with dip chemical for use during milking.

When the milking is completed switch Off air supply.

MAINTENANCE

CLEAN THE DIP CUPS DAILY by detaching from gun, unscrewing the bottle then rinsing the cup out with clean warm water to remove any hairs, dirt, etc.

Use ONLY a soft dry cloth to clean the pneumatic enclosure housing when necessary – NEVER use a hose. If the supply cord is damaged, it must be replaced by the manufacturer, its service agent or similarly qualified persons in order to avoid a hazard.

Fig. 2

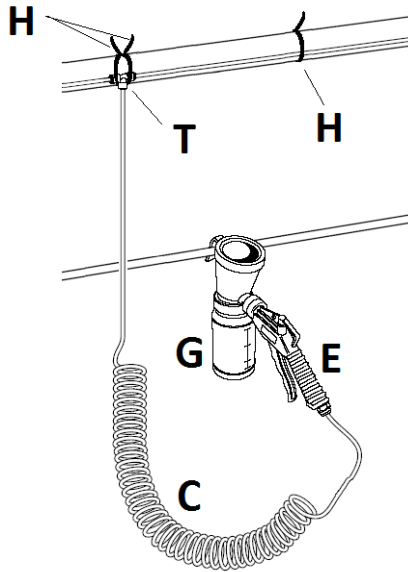

Fig. 3 DIPPING CUP

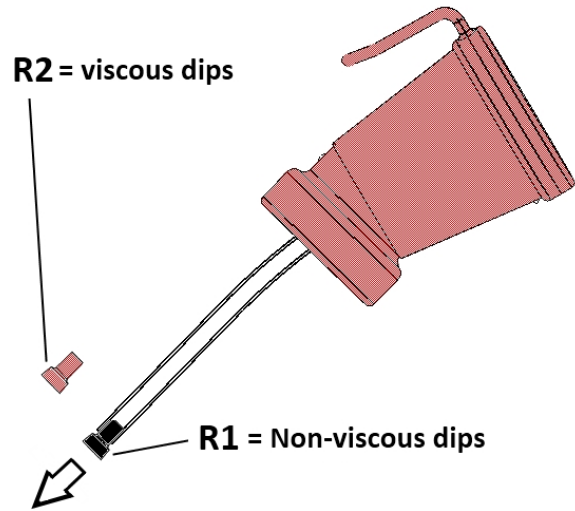

Fig. 5

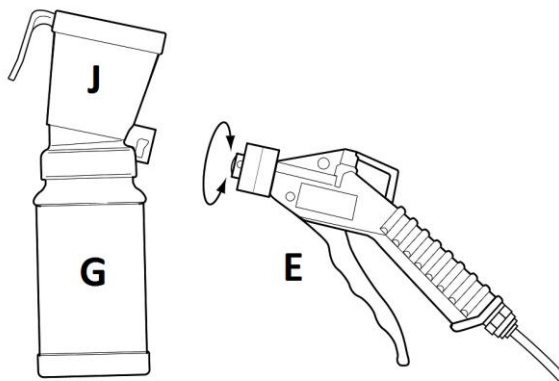
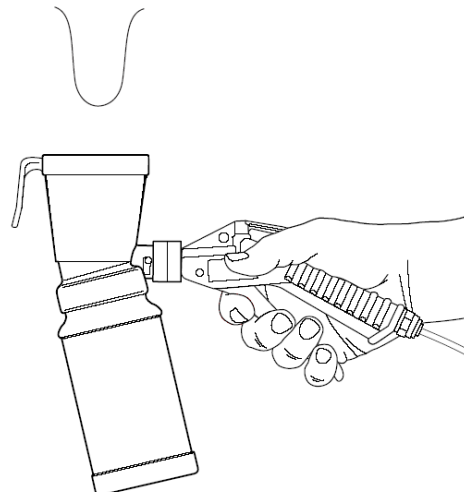

Fig. 6



SPECIFICATIONS

Power Source	– Air – Farm Compressor	• 8 Litres/minute minimum
	– Operating Pressure	• 3 - 4 psi (0.2 - 0.28 bar) Max.
Output	– Air	• 5 – 8 L/min at 3 - 4 psi (0.28 Bar max.)
Maximum No. of Applicators per Pumping Unit		• 10
Maximum No. of Applicators operating simultaneously		• 2
Maximum Length of Distribution Tubing		• 45 Metres
Typical Chemical Consumption per Applicator (Dip)		• 10 -15 mL/second
Operating Temperature		• 5 – 40 °C

PROBLEMS & FAULT FINDING

Problem	Likely Cause	Probable Solution
No Dip appears in cup when gun trigger squeezed (ALL units)	No Air Supply present	<p>Switch On Mains electricity supply to compressor and check that tap at regulator in ON position.</p> <p>Observe the Pressure Gauge of regulator. Disconnect the distribution tube at the outlet of the Regulator. If plenty of air exits from fitting then it is probable that the distribution tubing is blocked, or restricted by over-tight cable ties.</p> <p>Check for leaking connections on distribution tubing system – especially that tube fully pushed into fittings.</p>
No Dip appears in cup when gun trigger squeezed (at ONE unit only)	Air supply not reaching applicator.	<p>Leaking connections, or blocked tubing – check and remedy.</p> <p>Trigger valve stuck or blocked – check valve and lubricate with silicone aerosol.</p> <p>Cup entry/tubing dirty or blocked – clean to remove dirt, or replace with new cup.</p>

DRILLING TEMPLATE - Use the template below to mark out fixing holes for the pump.

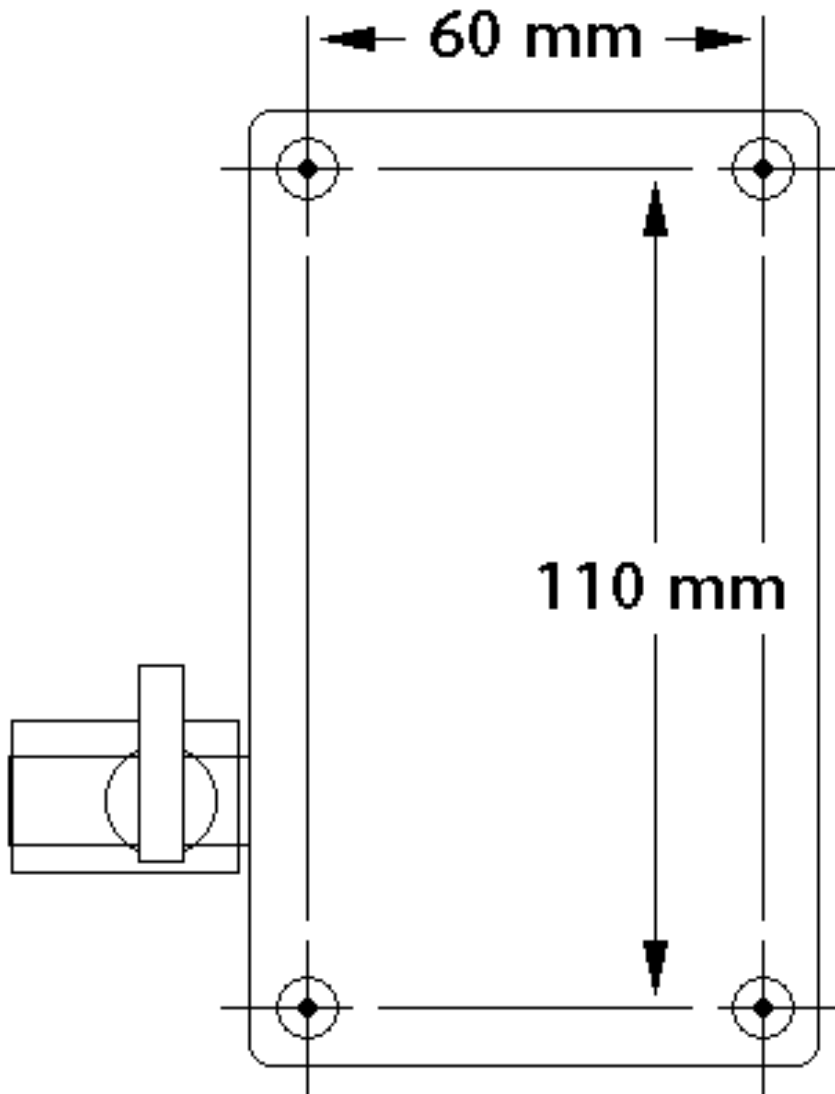



Ambic Equipment Limited,
One Parkside, Avenue Two Station Lane,
Witney, Oxfordshire, OX28 4YF, England
Tel: +44 (0)1993 776555 Fax: +44 (0)1993 779039
www.ambic.co.uk