

APF016 - POWERFOAMER PRESSURE SWITCH KIT

In the event that the air pump runs continuously – FIRST CHECK FOR LEAKS – both inside and outside of the electrical enclosure. If no leaks are found, then it is most likely that the pressure switch is faulty and should be replaced with this kit (see diagram opposite).

The kit comprises 4 pieces (3 of which are ready-bonded together):-

1. Pressure Switch (preset to ~3psi)
2. T-piece (Nickel/Brass)
3. Elbow for 6mm bore tubing
4. 6mm /1/8" BSP Quick-release Connector

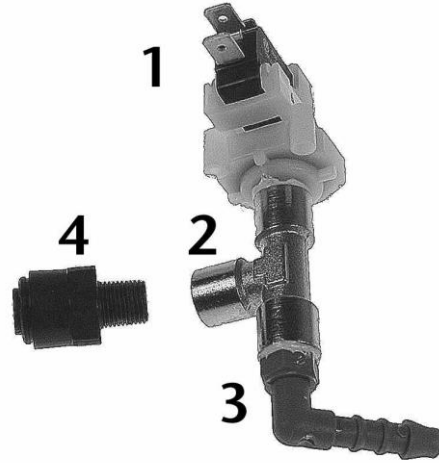

WARNING - THIS COMPONENT MUST BE REPLACED BY A COMPETENT ELECTRICIAN. BEFORE ATTEMPTING ANY SERVICE OF THE ELECTRICAL ENCLOSURE, DISCONNECT FROM MAINS POWER.

- a) Remove lid of enclosure and disconnect leads to existing Pressure Switch (noting positions).
- b) Disconnect air outlet pipe from existing 6mm connector.
- c) Unscrew connector (4), whilst holding the T-piece firmly (many connectors are sealed with Loctite and may snap off during removal). Warm PVC tube and remove it from the elbow.
- d) Fit PVC tube onto new elbow (3) making sure that this action does not disturb the tube sealing onto non-return valve, or pump.
- e) Apply silicone sealant or PTFE tape to threads of new connector (4), place in position through from outside of case and align with side branch of T-piece. Hold T-piece (2) in correct position whilst tightening the quick release connector (4) firmly – do NOT over-tighten.
- f) Refit leads to pressure switch – including the "Blank" connector on the central connection.
- g) Refit lid of enclosure.
- h) Refit the air Outlet tubing to the new connector making sure that the tubing is pushed well home (at least 15mm entry distance).

APF016 - POWERFOAMER PRESSURE SWITCH KIT

In the event that the air pump runs continuously – FIRST CHECK FOR LEAKS – both inside and outside of the electrical enclosure. If no leaks are found, then it is most likely that the pressure switch is faulty and should be replaced with this kit (see diagram opposite).

The kit comprises 4 pieces (3 of which are ready-bonded together):-

1. Pressure Switch (preset to ~3psi)
2. T-piece (Nickel/Brass)
3. Elbow for 6mm bore tubing
4. 6mm /1/8" BSP Quick-release Connector

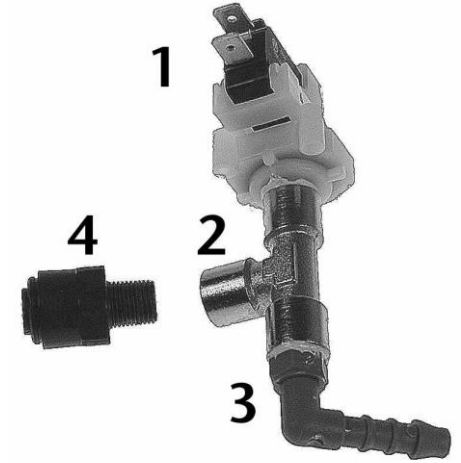

WARNING - THIS COMPONENT MUST BE REPLACED BY A COMPETENT ELECTRICIAN. BEFORE ATTEMPTING ANY SERVICE OF THE ELECTRICAL ENCLOSURE, DISCONNECT FROM MAINS POWER.

- a) Remove lid of enclosure and disconnect leads to existing Pressure Switch (noting positions).
- b) Disconnect air outlet pipe from existing 6mm connector.
- c) Unscrew connector (4), whilst holding the T-piece firmly (many connectors are sealed with Loctite and may snap off during removal). Warm PVC tube and remove it from the elbow.
- d) Fit PVC tube onto new elbow (3) making sure that this action does not disturb the tube sealing onto non-return valve, or pump.
- e) Apply silicone sealant or PTFE tape to threads of new connector (4), place in position through from outside of case and align with side branch of T-piece. Hold T-piece (2) in correct position whilst tightening the quick release connector (4) firmly – do NOT over-tighten.
- f) Refit leads to pressure switch – including the "Blank" connector on the central connection.
- g) Refit lid of enclosure.
- h) Refit the air Outlet tubing to the new connector making sure that the tubing is pushed well home (at least 15mm entry distance).